



Oosterhout, Nederland

GEZE Slimdrive EMD/-F, F-IS, Invers

Electromechanical drive for hinged doors



BEWEGUNG MIT SYSTEM

Automation with soundless ease

The electromechanical drive GEZE Slimdrive EMD for swing doors is a system full of concentrated technology which – like all products in the Slimdrive range – manages to do its job with a construction height of only 7 cm.

The reliable operation of the drive is achieved with a maintenance-free high performance motor with low wear characteristics and state-of-the-art control technology. An intelligent communication is possible through the CAN interface. It also means simple wiring, for example when double doors, doors to draught-lobbies or lobby controls are involved.

Therefore, if functionality, efficiency and low-noise disturbance are requested, the Slimdrive EMD is the ideal product to be installed. The range of applications is extensive: facilities, office buildings, hotels and even hospitals or nursing homes are possible areas of application.

Further product options:

- ▶ **GEZE Slimdrive EMD-F**
Has received the approval for fire and smoke protection doors by the German Institution for Construction Technology (DIBt)^{*)}
- ▶ **GEZE Slimdrive EMD F-IS**
Containing an integrated closing sequence control for double-leaf swing doors and is suitable in particular for smoke and fire protection doors
- ▶ **GEZE Slimdrive EMD Invers**
Particularly well suitable for escape and rescue routes or smoke and heat extraction (RWA) installations

^{*)} Notice the admittance of the respective smoke and fire protection door.



GEZE Slimdrive EMD

Product features

- ▶ Slim construction height of just 70 mm
- ▶ Suitable also for large and heavy doors
- ▶ Installation possibilities: on hinge and opposite hinge side, as door leaf or transom mounting
- ▶ Certified according to DIN V 18650, as well as BGR 232
- ▶ Low Energy Function (DIN V 18650 resp. prEN 12650)
- ▶ Extremely quiet operation

Connection options

The Slimdrive EMD is easy to connect and can be controlled from all usual control elements.

- ▶ Suitable for all control elements such as e.g. buttons, key switches, radar or infrared movement sensors, radio/remote control etc.
- ▶ Separate input for internal and external sensors
- ▶ Safety sensors
- ▶ Emergency stop switch
- ▶ Programme switch or display programme switch
- ▶ Bolt switch contact
- ▶ Motorised lock
- ▶ All electrical door openers: AC or DC, static or current load (potential-free control)
- ▶ Power supply for electrical equipment (control elements, door opener etc.): 24 V DC, 1000 mA

Technical characteristics	Slimdrive EMD / EMD -F
Drive dimensions	70 x 120 x 650 mm (height x depth x width)
Closing force	EN 3-6 (EMD-F only)
Mains connection	230 V AC, 50/60 Hz
Leaf width	max. 1400 mm
Leaf weight	max. 180 kg (EMD), max. 230 kg (EMD-F)
Door opening angle	adjustable, up to 110°
Opening and closing speed	adjustable
Electrical latching force	adjustable
Activation delay	adjustable, 0 to 60 seconds
Hold-open time	adjustable, 0 to 60 seconds
Opening and closing process	track controlled

Installation

The same version can be used for all types of installation: left-hand and right-hand opening, mounting on the same as the opposite side of hinges

Mounting options

- ▶ on the hinge side:

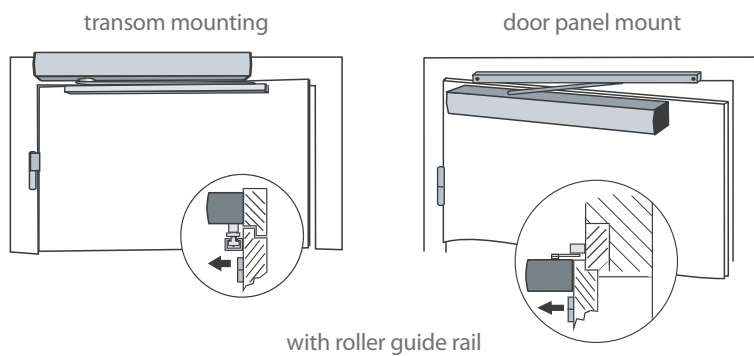

- ▶ on the opposite side of the hinges:

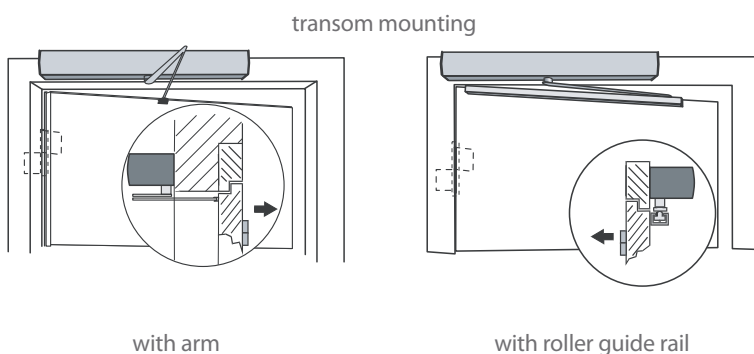

Functions

- ▶ Operating modes: permanently open, automatic, shop closed, night function
- ▶ Low-energy operation according to prEN 12650
- ▶ Recognition of obstacles and reversing action
- ▶ Dynamic adjustment of hold-open time
- ▶ Diagnostic function and error memory. For example for monitoring the safety sensors
- ▶ Master-slave operation for double-leaf doors
- ▶ Self-learning; e.g. the connected sensors are automatically recognised
- ▶ All attitudes are feasible via the display programme switch



GEZE GmbH

P.O. Box 1363
71226 Leonberg
Germany

GEZE GmbH

Reinhold-Vöster-Straße 21-29
71229 Leonberg
Germany
Telefon +49 (0) 7152-203-0
Telefax +49 (0) 7152-203-310

www.geze.com

GEZE branch offices

Germany

GEZE GmbH

Niederlassung Nord/Ost
Bühningstraße 8
13086 Berlin (Weissensee)
Tel. +49 (0) 30-47 89 90-0
Fax +49 (0) 30-47 89 90-17
E-mail: berlin.de@geze.com

GEZE GmbH

Niederlassung West
Nordsternstraße 65
45329 Essen
Tel. +49 (0) 201-83082-0
Fax +49 (0) 201-83082-20
E-mail: essen.de@geze.com

GEZE GmbH

Niederlassung Mitte
Adenauerallee 2
61440 Oberursel (b. Frankfurt)
Tel. +49 (0) 6171-63610-0
Fax +49 (0) 6171-63610-1
E-mail: frankfurt.de@geze.com

GEZE GmbH

Niederlassung Süd
Reinhold-Vöster-Straße 21-29
71229 Leonberg
Tel. +49 (0) 7152-203-594
Fax +49 (0) 7152-203-438
E-mail: leonberg.de@geze.com

GEZE subsidiaries

Germany

GEZE Sonderkonstruktionen GmbH
Planken 1
97944 Boxberg-Schweigern
Tel. +49 (0) 7930-9294-0
Fax +49 (0) 7930-9294-10
E-mail: sk.de@geze.com

GEZE Service GmbH

Reinhold-Vöster-Straße 35
71229 Leonberg
Tel. +49 (0) 7152-9233-0
Fax +49 (0) 7152-9233-60
E-mail: info@geze-service.com

GEZE Service GmbH

Niederlassung Berlin
Bühningstraße 8
13086 Berlin (Weissensee)
Tel. +49 (0) 30-470217-30
Fax +49 (0) 30-470217-33

Europe

Benelux

GEZE Benelux B.V.
Leemkuil 1
Industrieterrein Kapelbeemd
5626 EA Eindhoven
Tel. +31 (0) 40-26290-80
Fax +31 (0) 40-26290-85
E-mail: benelux.nl@geze.com

France

GEZE France S.A.R.L.
ZAC de l'Orme Rond
RN 19
77170 Servon
Tel. +33 (0) 1-60626070
Fax +33 (0) 1-60626071
E-mail: france.fr@geze.com

Great Britain

GEZE UK Ltd.
Blenheim Way
Fradley Park
Lichfield
Staffordshire WS13 8SY
Tel. +44 (0) 1543-443000
Fax +44 (0) 1543-443001
E-mail: info@geze-uk.com

Italy

GEZE Italia Srl
Via Giotto 4
20040 Cambiago (MI)
Tel. +39 02 95 06 95-11
Fax +39 02 95 06 95-33
E-Mail italia.it@geze.it

GEZE Engineering Roma Srl
Via Lucrezia Romana 91
00178 Roma
Tel. +39 06-7265311
Fax +39 06-72653136
E-mail: gezeroma@libero.it

GEZE Engineering Bari Srl
Via Treviso 58
70022 Altamura (Bari)
Tel. +39 080-3115219
Fax +39 080-3164561
E-mail: gezebari@libero.it

Austria

GEZE Austria GmbH
Mayrwiesstraße 12
5300 Hallwang b. Salzburg
Tel. +43 (0) 662-663142
Fax +43 (0) 662-663142-15
E-mail: austria.at@geze.com

Poland

GEZE Polska Sp. z o.o.
ul. Annopol 3 (Zeran Park)
03-236 Warszawa
Tel. +48 (0) 22-8142211
Fax +48 (0) 22-6142540
E-mail: geze@geze.pl

Switzerland

GEZE Schweiz AG
Bodenackerstrasse 79
4657 Dulliken
Tel. +41 (0) 62-285 54 00
Fax +41 (0) 62-285 54 01
E-mail: schweiz.ch@geze.com

Spain

GEZE Iberia S.R.L.
Pol. Ind. El Pla
C/ Comerç, 2-22, Nave 12
08980 Sant Feliu de Llobregat (Barcelona)
Tel. +34-(0) 9-02 19 40 36
Fax +34-(0) 9-02 19 40 35
E-mail: iberia.es@geze.com

Scandinavia

Sweden

GEZE Scandinavia AB
Mallslingan 10
Box 7060
18711 Täby
Tel. +46 (0) 8-7323-400
Fax +46 (0) 8-7323-499
E-mail: sverige.se@geze.com

Norway

GEZE Scandinavia AB avd. Norge
Postboks 63
2081 Eidsvoll
Tel. +47 (0) 639-57200
Fax +47 (0) 639-57173
E-mail: norge.se@geze.com

Finland

GEZE Finland
Branch office of GEZE Scandinavia AB
Postbox 20
158 71 Hollola
Tel. +358 (0) 10-400 51 00
Fax +358 (0) 10-400 51 20
E-mail: finland.se@geze.com

Denmark

GEZE Denmark
Branch office of GEZE Scandinavia AB
Møllehusene 3, 3. th.
4000 Roskilde
Tel. +45 (0) 46-323324
Fax +45 (0) 46-323326
E-mail: danmark.se@geze.com

Middle East

U.A.E.

GEZE Middle East
P.O. Box 17903
Jebel Ali Free Zone
Dubai
Tel. +971 (0) 4-8833112
Fax +971 (0) 4-8833240
E-mail: geze@emirates.net.ae

Asia

GEZE Industries (Tianjin) Co., Ltd.
Shuangchenzhong Road
Beichen Economic Development Area (BEDA)
Tianjin 300400, P.R. China
Tel. +86 (0) 22-26973995-0
Fax +86 (0) 22-26972702
E-mail: geze@public1.tpt.tj.cn

GEZE Industries (Tianjin) Co., Ltd.

Branch Office Shanghai
Rm. 3010 Building No. 2
3 Hongqiao Road
200030 Shanghai, P.R. China
Tel. +86-(0)21-52 34 09-60/-61
Fax +86-(0)21-64 47 20 07
E-mail: gezesh@geze.com.cn

GEZE Industries (Tianjin) Co., Ltd.

Branch Office Guangzhou
Room 1113, Jie Tai Plaza
218-222 Zhong Shan Liu Road
510180 Guangzhou
P.R. China
Tel. +86 (0) 20-813207-02
Fax +86 (0) 20-813207-05
E-mail: gezegz@public2.sta.net.cn

GEZE Industries (Tianjin) Co., Ltd.

Branch Office Beijing
No. 6-32 Building, Jili Avenue
Daxing District
Chaoyang District
Tel. +86-(0)10-87 97 51-77/-78
Fax +86-(0)10-87 97 51-71
E-mail: gezebj@geze.com.cn

GEZE Asia Sales Ltd.

No. 88-1-408, East Road
Free Trade Zone of Tianjin Port
Tianjin, P.R. China
Tel. +86 (0)22-26 97 39 95-0
Fax +86 (0)22 26 97 27 02
E-mail: geze@public1.tpt.tj.cn

GEZE Sonderkonstruktionen (Tianjin) Ltd.

No. 6-32 Building, Jili Avenue
Daxing District
Chaoyang District
100076 Beijing, P.R. China
Tel. +86 (0) 10-87 96 51-52
Fax +86 (0) 10-87 97 14-76

GEZE Representative